



## Loading Procedures and Safety



**Y**our press, dies, scale, primer tubes and tools are arrayed before you. You have selected a bullet, primer and powder charge combination to suit your particular application, and a gleaming tray full of clean, inspected brass awaits. Now what?

Your goal of course, is to assemble all of this stuff into safe, accurate and reliable ammo in the most effective manner possible. Full understanding of each of the loading operations and the adjustment of dies that perform them is key to success. The loading sequence can be broken down like this:

1. Resize and deprime.
2. Trim, if required.
3. Reprime.
4. Bell the case mouth to accept bullet entry.
5. Charge with propellant.
6. Seat the bullet.
7. Crimp.
8. Gauge and package.

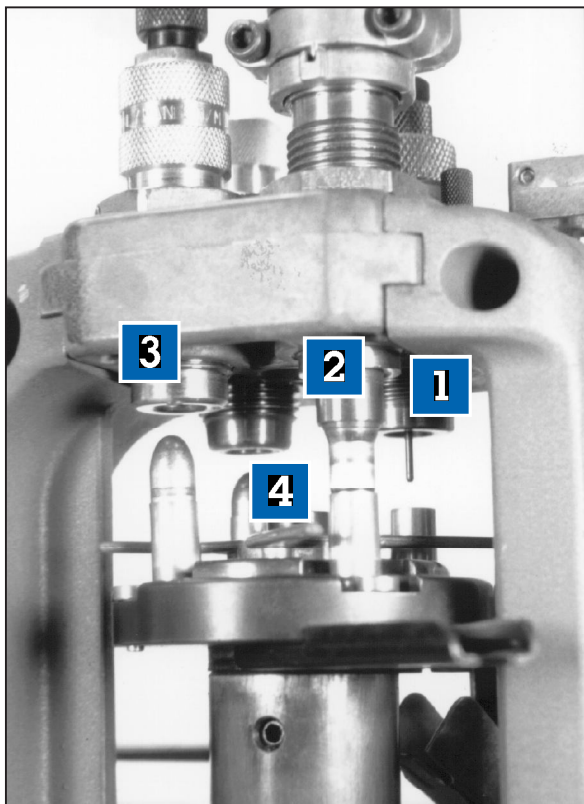

**Die stations:**

- 1-resize-deprime-reprime;
- 2-bell case mouth-charge;
- 3-seat bullet;
- 4-crimp.

## SIZING AND DECAPPING

Let's assume you are loading on a modern progressive press (we're using a Dillon 550B). Be sure to select the correct shell plate for the cartridge you're loading. Dies for straight walled cases should be screwed down to lightly contact the shellplate. (Pressure exerted on the base of the die can crack the carbide insert.) For bottlenecked





cases, dies are also generally screwed down all the way, but there are exceptions. Read and follow your die set manufacturers' adjustment instructions. Tighten the locking ring against the tool head while sizing a case. This will aid concentricity between the shell plate and sizer die. The decapping pin should clear the base of a case by 1/8" or so, while its supporting head shouldn't contact inside the case head. Run a few cases to check for proper sizing and concentricity. Resizing causes the case to grow longer.

## REPRIMING

Repriming is accomplished on the return stroke. Learn the "feel" required to seat a primer to proper depth, about .004" below flush. Loose primer pockets will become noticeable to you as you load; those should be culled aside for practice only, or discarded. You will see a difference between primers; the heavier cups on magnum and rifle primers cause them to seat "harder" than pistol primers.

**Caution** - prime in a smooth and controlled way. Jerky slamming can cause detonation.

Generally, trimming to length isn't required for straight walled pistol cases. Tapered, bottlenecked cases tend to stretch as the shoulder is blown forward and sized back with each use. Case length affects headspace and/or crimping dimensions. Cases should be gauged and sorted by length for critical applications where crimp consistency is required, while over length brass should be trimmed to specified length. (Too short cases shouldn't be used, particularly in auto pistol calibers that headspace on the case mouth!) Trimming is done before repriming. Clean trimmed brass thoroughly before continuing. (Reprime after trimming and recleaning is done - with case actuated dies.)

## BELLING

On the Dillon machine, case mouth bell is performed in one operation with powder charge dropping, and the powder drop funnel doubles as an expander ball/flaring tool. Traditional 3-die sets include a separate expander/bell die. Either should be adjusted to provide just enough



bell to permit bullet seating without shaving or distortion. Excess case mouth flare needlessly works the brass while possibly causing eccentric bullet seating. You should start with .010" flare over case diameter and adjust up or down from there. Some sizer dies will reduce case body diameters under SAAMI specifications. The expander "ball" (or its equivalent surface on Dillon's powder funnel) is designed to regulate the bullet's bearing diameter of the case to prevent bulges, eccentricity and bullet distortion from too-tight a fit. Ideally, the inside diameter of a resized case below the mouth should measure .003" or so under actual bullet diameter. If your sizer runs small, use a powder funnel or expander ball to bring case diameter back to specs.

Whenever you test run a case to check bell, seating or crimp adjustments on a progressive press, resize a fired case as well. Simulating loading tension between the toolhead and ram is necessary to make accurate adjustments to the other die stations. (A note: case neck chamfer is not a substitute for proper belling and shouldn't be done for most handgun cartridges as chamfer can affect crimping.)

## **WEIGHING AND CHARGING**

The single most critical operation in reloading is the consistent function of the powder measure. It must drop exactly the desired charge weight every single time. Case-actuated bell-and-measure systems tend to require some maintenance and careful adjustment, so it's important for you to become totally familiar with your press' system. Be sure to read and follow your manufacturer's instructions before proceeding! On the other hand, manually operated measures are very reliable. They only require the reloader to manipulate measure and cases in a consistent manner. If you load on a single stage press, resist the temptation to drop charges by hand directly into cases arrayed in a loading block. Your chance of error is too great and the measure will likely throw inconsistent charges when hand held. Instead, always use a measure stand or charge from your press. To adjust your measure for a desired charge weight, first fill the measure to within 3/4" or so of the top. Since some powders are bulky and may settle some, it's a good idea to lightly shake down the powder column. As you load keep the measure "topped off," all done to help



insure consistent density and column weight. Now you are ready to weight charges and adjust your measure.

## A NOTE ON SCALES

Your powder scale is only as accurate as the environment in which it's used. It must be placed on a solid, level surface away from air currents or temperature extremes. As well, any scale that isn't calibrated against known test weights is a pied piper of potential disaster! Test and recalibrate both scale and measure before each reloading session. Variation from this practice is unacceptable.

Many bulky or oddly shaped propellants tend to measure somewhat inconsistently. It's common to see a variation of one or two tenths of a grain from one charge to the next with fluffy flake powders like Solo 1000 or Clays. This variation can affect velocity extreme spreads, and push given rounds over pressure at maximum loadings. Thus, one dropped charge won't necessarily indicate the weight you're actually getting. You should adjust to the average of 10 charges and reduce your load if any one charge exceeds the maximum.

## BULLET SEATING

Some 3 die sets incorporate the crimp and seat dies together into one. Whether loading progressively or on a single stage press, seating and crimping should always be performed as separate operations or bullet shaving and inconsistent crimp will result. Ideally a bullet should seat to preset depth in perfect alignment and concentricity to the case without shaving, damage, bulging or wrinkling of either component.

**Pay attention!**  
Left is .40 x .38,  
on right is .40 S&W case  
fired in a .45 auto.





### Factors that most influence bullet seating are:

1. Case inside diameter vs. bullet diameter ( $-.003/.004$ ").
2. Bell diameter and depth.
3. Seating punch cavity profile.
4. Initial manual alignment of bullet to case.
5. Crimp groove location, which predetermines overall length.

To start, match the seating punch to your bullet nose profile and install it backed out. This is very important to concentricity and alignment. Run an empty case into the seat die and back off the die body one turn from the point at which it crimps the case mouth. Carefully place a bullet onto the belled, uncharged case and run it into the seater. Measure the resulting overall length and adjust the seating punch down until the correct overall length is achieved. (Remember to run a fired case in the sizer each time you try a sample round in another die!) It's a good idea to run 4 or 5 more dummies to be certain of your overall length adjustments. Loading test dummies prevents you from accidentally shooting your mistakes.

### CRIMPING

In a four or five station progressive press (like the excellent Dillon 550B or 650) the last station is used to crimp. Even if you load on a single stage press, you should obtain a separate crimp die so you don't have to worry about having to readjust your combo seat and crimp die for each reloading cycle. Adjustment of a standard crimp die is very simple. Determine the correct crimp/case mouth diameter from the specifications for your cartridge. (Your die's instructions may have a set procedure for crimping. Back this up by measurement and never crimp smaller than the values stated in this reloading manual!) With a dummy round in the crimp station, screw the crimp die down until you feel the die's crimp ring contact the case mouth. Lower the ram and screw the die down in small increments and repeat until you measure the crimp diameter called for. Tighten the die's locking ring and test a few more dummy rounds to verify your



adjustment and you're done. Some dedicated crimpers (like the Lee factory crimp die) use a floating crimp ring which is adjusted by turning a screw ram in the die's body. The basic adjustment procedure is otherwise the same. Remember, variations in case length will affect crimp values, with shorter cases receiving less crimp.

### **A FEW MORE CLUES**

With everything adjusted and tightened down, you're almost ready to produce ammo. Once again, take a moment and refer to the safety procedure and checklists in this manual. You're not ready to do anything until you're ready to be safe. You might find it useful to run a few more dummy rounds and mark them for future reference. They will save time should you need to readjust your press to duplicate that load.